



	Fresh Water	Pool Water	Sea Water	220-240 V	400 V	110-120 V	50 Hz	60 Hz	12 V AC	24 V DC	DMX	DMX/RDM	Plug and Spray
Fountain Flame 24V/DMX/02	✓	✓*	✓	✓	✓	✓	✓	✓	✓	✓	✓	✓	✓
Fountain Flame/DMX/02/V2	✓	✓*	✓	✓	✓	✓	✓	✓	✓	✓	✓	✓	✓

\*max. 0.45 mg/l free chlorine

## FOUNTAIN FLAME 24V/DMX/02

## FOUNTAIN FLAME/DMX/02/V2

The Fountain Flame produces spectacular special effects of light, water and fire. The gas flame burns on top of the variable jet. The handy unit is powered by the 24V or 230V Technology.

The Fountain Flame system is developed in cooperation with TBF-PyroTec, who contributed the ignition, burner and gas technology. These are integrated with OASE's DMX-controlled Varionaut pumps, LED Lighting and special nozzle to create fascinating special effects combining water and fire. The freely programmable Fountain Flame, the water along with the flame,

reaches a height of up to 8 m. The fire is carried up by the water. The RGB LED-ProfiLux-lights illuminate the fountain jet individually. The ignition burner and the flame adjustment are also controlled via DMX. Thereby a variety of combined effects can be achieved with water and fire creating endless possibilities. The running flame can also be projected on a water jet parabola. This system is available as a fixed installation or as a mobile device. The Fountain Flame is designed for use in fresh water and pool water\* and has a waterproof 24V DC power connection for illumination and a waterproof DMX data connection. The Fountain Flame is DMX / RDM capable.

### NEW



Fountain Flame/DMX/02/V2

### Product characteristics at a glance

- Continuously DMX-controlled fire – water fountain with a jet height up to 8 m with 230 V Version
- Continuously DMX-controlled fire – water fountain with a jet height up to 2.8 m with 24V Version
- RGB LED spotlights to illuminate the fountain jet with DMX
- DMX-controlled ignition burner and flame adjustment
- Large variety of combined fire and water effects, and even more to discover
- The running flame can also be projected on a parabolic jet of water

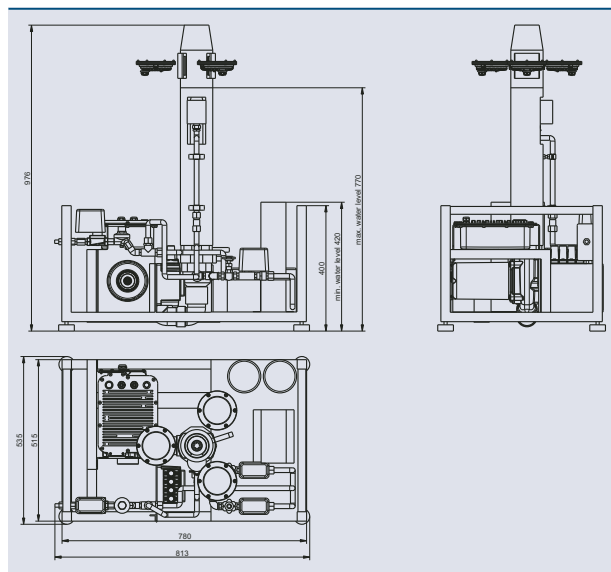
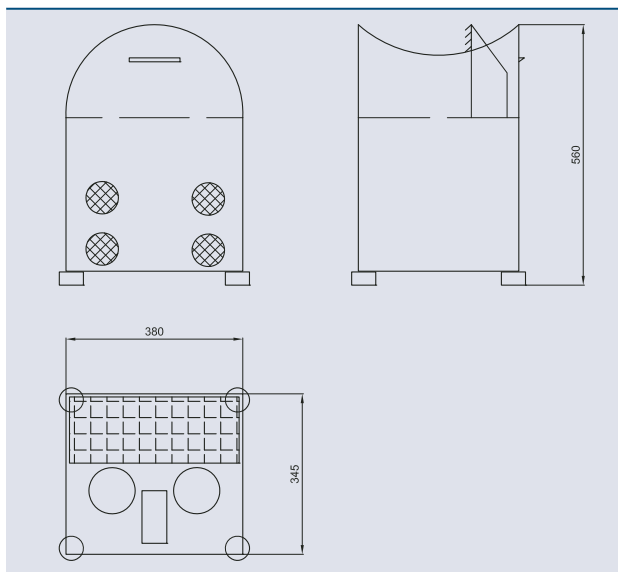

### Scope of delivery 24 V-Version (58905)

- 1 x 50665 Varionaut 150 24V/DMX/ 02
- 1 x 50723 Comet 15-17 Silver
- 2 x 56267 ProfiLux 110/DMX/02
- 1 x 50720 Underwater LED Driver /DMX/02
- 1 x 50733 Underwater Power Supply 250 24V/ DMX/02
- 1 x Flame System 24V (320 x 200 x 150 [mm])
- 1 x pipe paket of 5 m

Only propane butan gas (2.5 to 4 kg/h) at 3 bar  
Not suitable for natural gas.

Fountain Flame 24V /DMX/02		
Dimensions (L x W x H) without pump	[mm]	380 x 345 x 560
Order no.		58905

Fountain height	Comet 15-17 on Varionaut 150 24V/DMX/02		Comet Prec 20-20 Silver on Varionaut 365 / DMX / 02	
	l/min	bar	l/min	bar
0.50 [m]	42	0.06	–	–
0.75 [m]	52	0.09	–	–
1.00 [m]	62	0.11	90	0.12
1.25 [m]	69	0.14	96	0.14
1.50 [m]	76	0.17	102	0.17
1.75 [m]	82	0.19	110	0.19
2.00 [m]	89	0.22	117	0.22
2.50 [m]			132	0.28
3.00 [m]			147	0.34
3.50 [m]			160	0.40
4.00 [m]			170	0.46
5.00 [m]			206	0.57
6.00 [m]			227	0.69
7.00 [m]			245	0.81
Material	Stainless steel			
Weight Comet [kg]	0.86		1.55	
Weight Varionaut [kg]	5		17	
Order no.	50724 + 50665		50523 + 50526	

### Scope of delivery 230 V-Version (58905)

- 1 x 50526 Varionaut 365 / DMX/ 02
- 1 x 50523 Comet Prec 20-20
- 3 x 50717 ProfiLux 320 /DMX/02
- 1 x 50720 Underwater LED Driver /DMX/02
- 1 x Flame System

Only propane gas (5 to 7.5 kg/h) at 3 bar  
Not suitable for natural gas.

Fountain Flame /DMX/02		
Dimensions (L x W x H) without pump	[mm]	813 x 535 x 976
Order no.		58905