

Fresh Water	Pool Water	Sea Water
		

## FLOOR DRAIN ARMATURES

Concrete or liner pools can be easily emptied via OASE floor drains. The drains are available with plug or with sieve.

Subsurface installation of a slide valve is required for discharging the models with debris sieve. Suitable cover sieves for the floor drains prevent excessive debris from getting into the drain (accessories).

The floor components of the drain armatures have concrete sealing flanges and can simply be inserted and cemented into the muffs of the drain pipes. Appropriate bores are available for connection to the equipotential bonding.

Appropriate liner clamping flanges with seal and bolts are available for flanging and sealing to liner. They are suitable for normal pool liner, with or without textile reinforcement and a maximum thickness of 2.5 mm, however they are not suitable for waterproofing membranes in accordance with DIN 18195.

**1** The concrete part is the basis of every configuration. Available for DN 70 and / or DN 100 pipes.

**2** The clamping flange is for fastening with liner. Products with cable transitions are listed on page 138.

**This position can be used optionally.**

**3** Depending on the requirement a decision is made at this point concerning the specific implementation: Plug, sieve, overflow or level regulator...

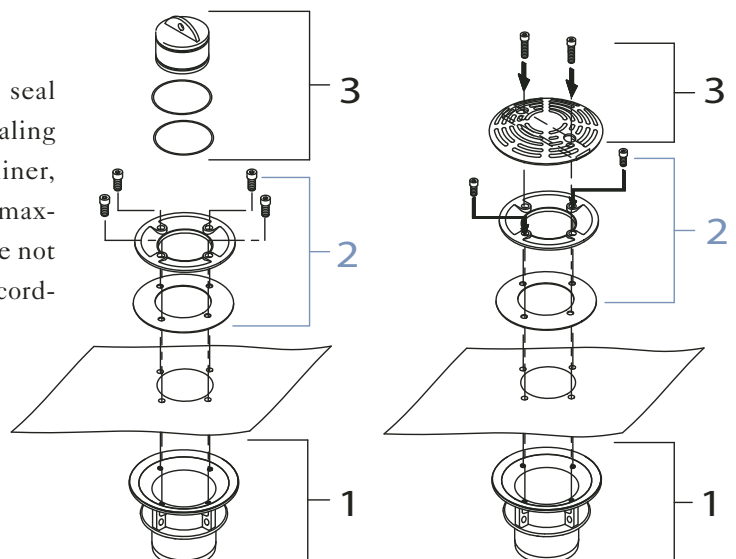

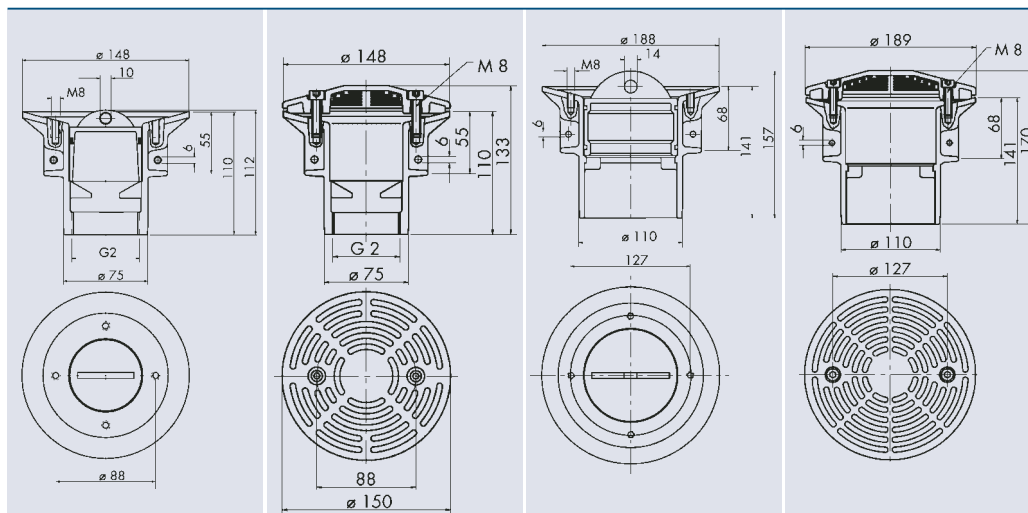

<h1>3</h1>				
	<b>Plug 70 T</b>	<b>Debris sieve 70 E</b>	<b>Plug 100 T</b>	<b>Debris sieve 100 E</b>
Dimensions (ø) [mm]	70	150	100	190
Designation	plug	debris sieve	plug	debris sieve
DN	70	70	100	100
Material	Tombac	Stainless steel 1.4301 (AISI 304)	Tombac	Stainless steel 1.4301 (AISI 304)
Weight [kg]	0.6	0.6	0.9	0.7
<b>Order no.</b>	<b>57468</b>	<b>51973</b>	<b>57462</b>	<b>51974</b>

<h1>2</h1> (optional)		
	<b>Liner clamping flange 70 T</b>	<b>Liner clamping flange 100 T</b>
Dimensions (ø) [mm]	148 x 26	188 x 35
Designation	liner clamping flange	liner clamping flange
DN	70	100
Material	Tombac	Tombac
Weight [kg]	1.1	1.4
<b>Order no.</b>	<b>51108</b>	<b>51117</b>

<h1>1</h1>		
	<b>Concrete part 70 T</b>	<b>Concrete part 100 T</b>
Dimensions (ø x H) [mm]	70 x 110	100 x 141
Designation	concrete part	concrete part
DN [mm]/[inch]	70 / 2"	100
Material	Tombac	Tombac
Weight [kg]	2.1	3.2
<b>Order no.</b>	<b>57471</b>	<b>57467</b>