



	Fresh Water	Pool Water	Sea Water	220-240 V	400 V	110-120 V	50 Hz	60 Hz	12 V AC	24 V DC	DMX	DMX/RDM	Plug and Spray
BT 2.2 - 40 to BT 22.0 - 125 IE3													

## BT 2.2-40 TO BT 22.0-125 IE3

BT block centrifugal pumps are strong, uncomplicated pumps that are used wherever space is limited.

### Product characteristics at a glance

- Dimensions and connections in accordance with DIN standards
- Motor in accordance with new IE3-Technologie
- Maintenance-free slide ring seal
- Enclosed impeller with high efficiency
- Dry installation only
- IP 55 rated

Thanks to their compact design they have very small space requirements. All dimensions and connections are DIN standard; this ensures universal implementation. BT block centrifugal pumps are normal suction centrifugal pumps in spiral housings for dry installation with a motor in accordance with IEC standards. They comprise few parts that are important for their function, which reduces maintenance work to a minimum.



**NEW**

BT 2.2-40-4

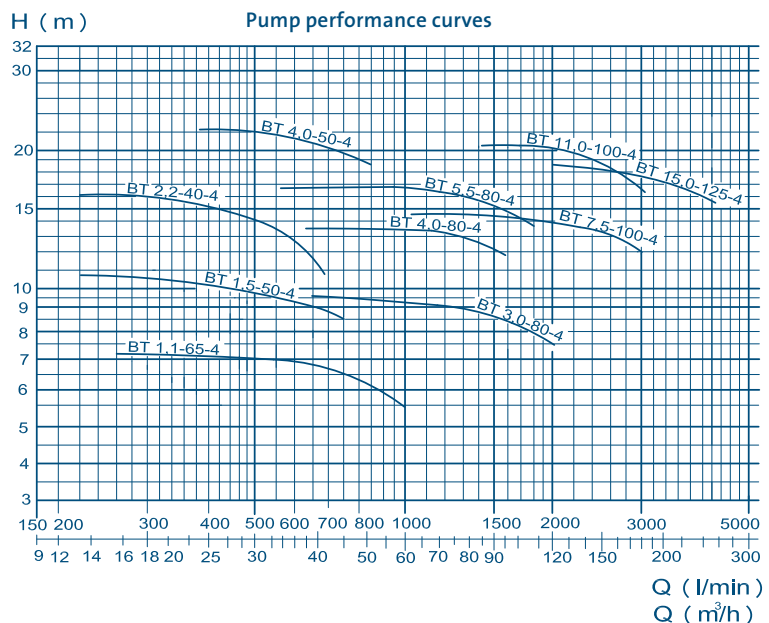

The few maintenance tasks that are necessary are executed quickly and easily. Thanks to the low rpm the pumps are very quiet in operation and are more durable. The enclosed impeller is highly efficient.

The robust BT block centrifugal pumps are delivered as standard in grey cast iron. Upon request these pumps can also be delivered in special materials, such as an impeller as bronze.

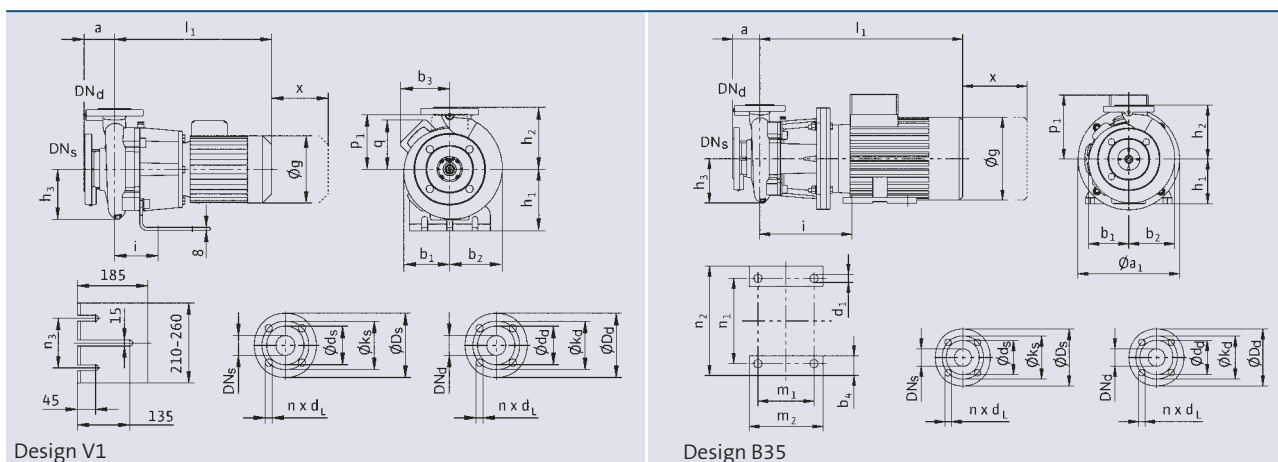

IE 3		2.2-40-4	1.5-50-4	4.0-50-4	1.1-65-4	3.0-80-4	4.0-80-4	5.5-80-4	7.5-100-4	11.0-100-4	15.0-125-4
Dimensions (LxWxH)	[mm]	611x360x296	556x340x274	696x405x360	564x360x298	653x385x356	733x450x367	789x382x367	795x412x410	832x440x432	1011x515x514
Power output	[kW]	2.20	1.50	4	1.10	3	4	5.50	7.50	11	15
Current	[A]	4.90	3.60	8.20	2.30	6.50	8.20	11.10	14.90	22.00	29.80
Voltage	[V/50 Hz]	400	400	400	400	400	400	400/YD	400/YD	400/YD	400/YD
Design		V1	V1	V1	V1	V1	V1	B35	B35	B35	B35
DN5	[mm]	65	65	65	80	100	100	100	125	125	150
DNd	[mm]	40	50	50	65	80	80	80	100	100	125
a	[mm]	100	100	100	100	125	125	125	125	140	140
a1	[mm]							300	300	350	350
b1	[mm]	145	127	174	136	160	170	170	176	200	252
b2	[mm]	151	147	186	162	196	197	197	211	232	294
b3	[mm]		144		144	155					
b4	[mm]							53	53	60	60
d1	[mm]							12	12	15	15
g	[mm]	217	193	246	193	220	246	276	312	312	312
h1	[mm]	180	160	200	160	180	200	132	132	160	180
h2	[mm]	180	180	225	200	225	250	250	280	280	355
h3	[mm]	145	152	179	155	178	178	178	196	219	250
i	[mm]	124	122	131	130	137	143	318	311	383	345
l1	[mm]	512	455	621	463	528	633	663	698	745	831
n3	[mm]	180	130	180	130	130					
m1	[mm]							140	178	210	254
m2	[mm]							180	218	256	300
n1	[mm]							216	216	254	254
n2	[mm]							256	256	300	300
p1	[mm]	160		188			188	188	250	250	250
q	[mm]		144		144	155					
x	[mm]	105	120	110	120	135	120	120	120	130	170
Ds	[mm]	185	185	185	200	220	220	220	250	250	285
ks	[mm]	145	145	145	160	180	180	180	210	210	240
ds	[mm]	118	118	118	132	156	156	156	184	184	211
ns	[mm]	4	4	4	8	8	8	8	8	8	8
dLs	[mm]	19	19	19	19	19	19	19	19	19	23
Dd	[mm]	150	165	165	185	200	200	200	220	220	250
kd	[mm]	110	125	125	145	160	160	160	180	180	210
dd	[mm]	84	99	99	118	132	132	132	156	156	184
nd	[mm]	4	4	4	4	8	8	8	8	8	8
dLd	[mm]	19	19	19	19	19	19	19	19	19	19
Material		GG	GG	GG	GG	GG	GG	GG	GG	GG	GG
Weight	[kg]	76	60	96	61	95	106	143	156	215	245
Order no.		45305	45306	45307	45308	45309	45310	45311	45312	45313	45314