



	Fresh Water	Pool Water	Sea Water	220-240 V	400 V	110-120 V	50 Hz	60 Hz	12 V AC	24 V DC	DMX	DMX/RDM	Plug and Spray
AirFlo 1.5 kW	✓	✓	✓	✓	✓	✓	✓	✓	✓	✓	✓	✓	✓
AirFlo 4.0 kW	✓	✓	✓	✓	✓	✓	✓	✓	✓	✓	✓	✓	✓
StrataFlo 2 HP	✓	✓	✓	✓	✓	✓	✓	✓	✓	✓	✓	✓	✓
StrataFlo 5 HP	✓	✓	✓	✓	✓	✓	✓	✓	✓	✓	✓	✓	✓

## AIRFLO 1.5 kW/4.0 kW, STRATAFLO 2 2HP/5HP (3-PHASE)

Air Flo sets new standards in the field of lake aeration and decoration: The axial propeller technology ensures impressive and unequalled water flow rates of up to 295,000 l/h – for an optimal supply of oxygen to the lake.

### Product characteristics at a glance

- Floating aerator for oxygen supply through powerful water patterns for water surfaces up to 15,000 m<sup>2</sup>
- Axial propeller technology for water flow rates up to 295,000 l/h
- Maximum oxygen supply for the body of water

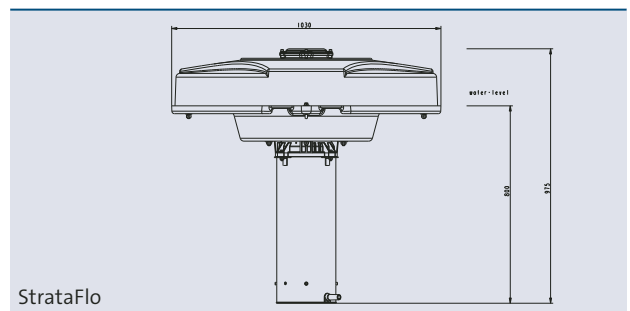
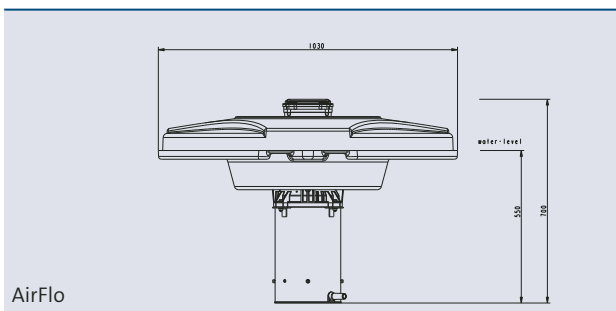



**Bayonet technology**  
for easy mounting.



**Fastening material**  
Easy and secure anchoring of the aerator thanks to the fastening material included in the scope of delivery. (3 x 30 meter, 3 mm thick)



**Earthing pin plug + control box**  
The 230V version is delivered ready to operate with control box.

**CEE-connector + protection switch**  
The 400 version comes with a ready to connect, 5 pole CEE connector and motor protection switch.

- Easy installation and maintenance through bayonet technology
- Foamed float for extraordinary stability and noise reduction
- Pump basket of corrosion resistant stainless steel
- Included in the scope of delivery: Fastening set, 3 -part nozzle attachment for 3 different types of water pattern "Trumpet"
- Lighting sets with stainless steel holder available as an accessory

**Illumination Set MIDI / MAXI / AirFlo LED/01**

For an impressive floating fountain even at night – as easy as our proven AirFlo system, we offer you a LED version of our illumination kit with three spotlights each. A unique connection system makes it very easy to install the spotlights on the float. The UST 150 transformer is mounted easily to the pump basket directly.



Illumination Set MIDI / MAXI / AirFlo LED/01

**Set of 3 LED**

- 3 x LunAqua 10 LED, each with a 10 W LED bulb
- 3 x Light mounting brackets
- 1 x Special stainless steel holder for fastening the transformer
- 1 x Safety transformer 150 VA, 230 V-12 V, 50 Hz incl. 50.0 + 2.0 m cable

**Order no.** 50479

Powerdata of the different water patterns	AirFlo 1.5 kW / 230V	AirFlo 4.0 kW / 400V		StrataFlo 2 HP	StrataFlo 5 HP (3-Phase)
Water pattern Fountain H x W* [m]	0.8 x 3.5	1.5 x 6.0	[ft]	3 x 12	5 x 20
Flow rate [l/h]	165000	295000	[gpm]	700	1250
<b>Lake size</b>					
Minimum lake size [m <sup>2</sup> ]	100	500	[sq.ft]	108	538
Opt. effect for lakes up to [m <sup>2</sup> ]	5000	15000	[sq.ft]	53800	16200
Suction depth max. [m]	4.0	5.0	[ft]	13.1	16.4

	AirFlo 1.5 kW / 230V	AirFlo 4.0 kW / 400V		StrataFlo 2 HP	StrataFlo 5 HP (3-Phase)
Dimensions (ø x H) [mm]	700 x 1150	950 x 1150	[inch]	46 x 28	46 x 38
Nominal voltage [V/Hz]	230/50	400/50	[V/Hz]	230/60	200-230/60
Pump power [KW]	1.5	4.0	[W/A]	2749/13.2	3738/19.8
Nominal current [A]	10.2	9.6	[W/A]	2749/13.2	3738/19.8
Minimum water depth [m]	0.90	1.15	[ft]	3	4
Cable length [m]	50.0 + 2.0	50.0 + 2.0	[ft]	160	160
Weight [kg]	ca. 40.0	ca. 60.0	[lbs]	88	132
<b>Order no.</b>	<b>50183</b>	<b>50185</b>		<b>50272</b>	<b>50274</b>