



	Fresh Water	Pool Water	Sea Water	220-240 V	400 V	110-120 V	50 Hz	60 Hz	12 V AC	24 V DC	DMX	DMX/RDM	Plug and Spray
UWS TS 111													

## UWS TS 111

These underwater spotlight has been designed with extra strength for professional use in public installations. In underwater operation they effectively set the stage for fountains and water features, out of the water they illuminate sculptures, buildings, or trees.

The spotlight housing is made of cast tombac and has a PG 16 cable gland for UWS TS 111. Halogen reflector bulbs are protected by a 15 mm thick, shatterproof safety glass lens, which is screw-fastened to the housing. The smooth surface ensures long cleaning intervals. The UWS TS 111 spotlight can be turned in all directions by 12.5° in its stainless steel installation housing. Two clamp rings enable precise alignment on site.

### Product characteristics at a glance

- Extremely robust tombac and stainless steel design
- Safety glass cover
- Flat surface for easy cleaning
- Extremely corrosion resistant
- Can also be used out of the water
- Supplied exclusive of connection cable, transformer, and bulb

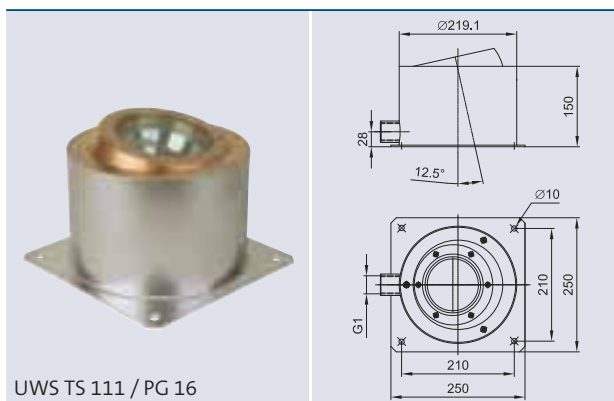

UWS TS 111 / PG 16

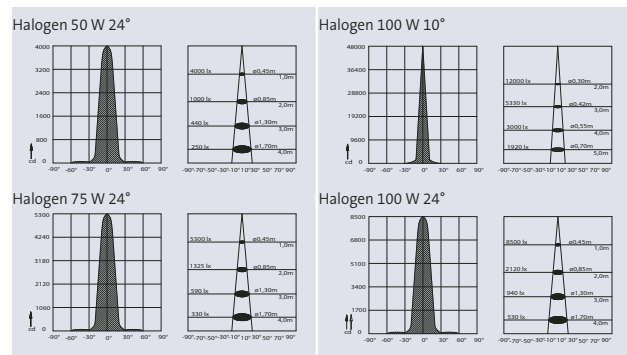

### Accessories for UWS T 111 (must be ordered separately)

Halogen reflector bulb 12 V				
Colour	white	white	white	white
Power Output [W]	50	75	100	100
Beam angle	24°	24°	10°	24°
Order no.	52939	52941	52942	52943

Underwater transformer UST 150/01 (see page 190) 50401

Underwater transformer UST 150/A/01 (see page 190) 50517

Connecting cable 12V AC/01 (see page 160) **Order no.**

Cable 12V AC /3.0 m/01 12374

Cable 12V AC /7.5 m/01 12375

Cable 12V AC /15.0 m/01 11740

Power Box 12V AC/01 (see page 160) 50492

UWS TS 111. Delivered without bulb, transformer and cable		
Dimensions (ø x H)	[mm]	219 x 155
Nominal voltage	[V]	12
Power consumption	[W]	50, 75 or 100
Light intensity	[cd]	4500 – 50000
Beam angle	[°]	10 or 24
Protection class		IP 68
Cable inlets		1 x PG 16
Material		Tombac/stainless steel brass/1.4571 (AISI 316Ti)
Cable length		–
Weight	[kg]	11.0
Order no.		52909